

New Brunswick's new transit village  
creates a smart new crossroads for the city and the area.

# It Takes a Village

BY J. BENJAMIN ALPER, P.E., WITH CAWSIE JIJINA, P.E.,  
AND FORTUNATO ORLANDO, P.E.

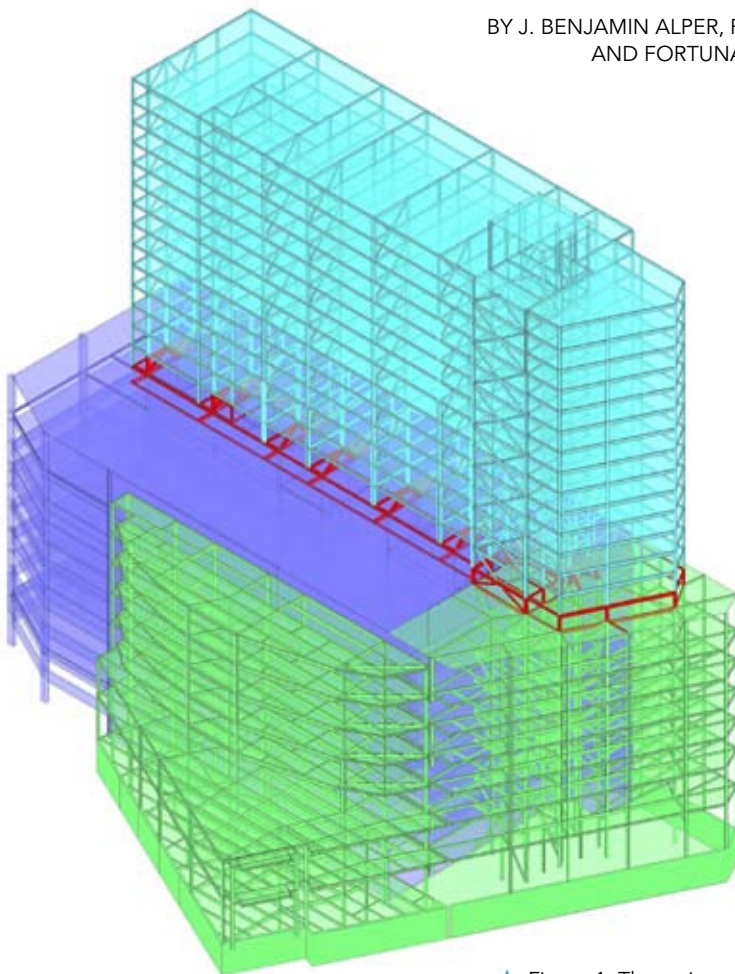

- PRECAST PLANK ON STEEL FRAME
- TRANSFER LEVEL WITH STEEL TRUSSES
- METAL DECK WITH CONCRETE ON STEEL FRAME
- PRECAST CONCRETE STRUCTURE

▲ Figure 1: The various structural systems in the building.

## WHAT IS "SMART" development?

There are several answers to that question, but perhaps one of the most intuitive ones is development that is centered around or in close proximity to mass transit.

Such development is the goal of the New Jersey Department of Transportation's Smart Growth initiative. In pursuing this goal for the town of New Brunswick, N.J., the New Brunswick Development Corp (DEVCO) created a mixed-use structure that would become a new epicenter for transit in the area, and in the process help revitalize the town center itself.

The project, the New Brunswick Gateway Transit Village (NBGTV), is a 632,000-sq.-ft, 300-ft-tall, mixed-use building that features parking, rental apartments, condominiums, office space and retail space. It also includes a promenade that extends to a pedestrian bridge, which connects directly to the commuter rail platform used by both Amtrak and NJ Transit. Not only does the building sit in a prime location, between downtown New Brunswick and the campus of Rutgers University campus, it is also currently the tallest building in town. And its diverse demands are met by an equally diverse set of structural systems (see Figure 1).

## Podium

The main podium of the building is split between a parking garage and a retail/office space. The parking area, made of precast concrete, is ten levels tall and takes up approximately 40% of the total building area. The parking is wrapped on two sides by a seven-story office/retail building. Due to the clear spans required between columns, we designed this space to use a structural steel frame supporting a floor system composed of cast-in-place concrete on a composite metal deck. The office

space north of the garage was separated from the garage structure by an expansion joint, thereby minimizing the transfer of sound and vibration between the garage and the office space. The residential tower above the podium straddles both the west office/retail segment of the building and the garage. Placing an expansion joint between the west office/retail and the parking garage was not feasible, as it would have necessitated an expansion joint through the residential tower as well. Accordingly, the architects planned the areas adjacent to the garage as communal hallways and lobbies where sensitivity to sound and vibration is not as critical.

### Residential Tower

While the selection of the podium structure was largely predetermined, the selection of a structural system for the residential tower was not as intuitive. Approximately 75% of the residential tower footprint rests on the precast concrete garage structure below, while the other 25% rests on the structural steel office/retail space.

At the schematic design phase, the contractor's preference was to construct the residential tower using post-tensioned concrete. However, given the sheer weight of the tower structure and the subsequent demands on the structural transfer system, the post-tensioned system was deemed not feasible. In its place, we chose to go with a steel staggered truss system, which would allow for long clear spans within the residential floors and would negate the need for a transfer floor at the base. However, the proximity of Amtrak's power lines and the constraints of its easement regulations made lifting heavy trusses 300 ft in the air prohibitively expensive.

After weighing the various constructability concerns, a traditional structural steel frame (supporting precast plank) was selected as the final structural system for the residential tower. This system used few interior beams between column lines, thereby allowing the architects to increase the efficiency of the interior spaces. Since fewer beams were used (typically spaced at intervals of 24 ft to 36 ft), the architect was able to put all the beams on partition lines and use the full height of the space from top of plank to bottom of plank as the floor space; no drop ceilings were required. The dissimilarities between the parking layout and the residential layout necessitated the transfer of every single residential column, an endeavor accomplished by a deep structural steel transfer truss system—made up of six 65-ft-long main trusses, each weighing 32.5 tons—135 ft above ground level.



► Typical truss connections made with shop-welded full and partial penetration welds.

**J. Benjamin Alper** is an associate, **Cawsie Jijina** is a principal and **Fortunato Orlando** is an associate principal, all with Severud Associates. Severud Associates has designed over 14,000 complex and varied structures since 1928, from the Gateway Arch in St. Louis to Madison Square Garden and the Bank of America Tower in New York. The authors would like to note the contributions of Dr. Mohamed Arafa, P.E., Fianna Ouyang, P.E., Justin Lawson, Stephanie DeCruz and Gustavo Amaris to this article.







◀ Erection of a steel transfer truss.

### Quick Coordination

Project specifications for the New Brunswick Gateway Transit Village required both the structural steel and precast trades to attend regular coordination meetings with the design team. It was common for meetings to include representatives from the owners, architect, parking consultant, structural engineer, precast fabricator, precast engineer, steel fabricator, connection designer, steel detailer steel/precast erector and the general contractor. Meetings would often include reviewing a 3D structural model together, discussing structural analysis assumptions, reviewing steel-to-precast connection details, discussing conflicts between trades and any other issues that were outstanding. BIM and 3D modeling notwithstanding, we found that putting all the right parties in a room together is still the simplest way to achieve quick coordination and keep the project moving ahead.

◀ The project, under construction, with train station and Amtrak wires in the foreground.



### Lateral System and Transfer Structure

A combination of steel braced frames and moment frames provided lateral resistance in the residential structure. Shear walls and precast concrete frames accomplished the same in the parking garage segment below. All lateral forces were transferred directly from the steel braced frames of the residential tower to the transfer structure and from the transfer structure to the walls of the parking garage below.

By spanning the 10-in.-thick prestressed precast plank 36 ft between beam lines, the lines of residential steel framing, the steel braced frames and the transfer trusses were able to align with the precast concrete shear walls of the garage structure below. By aligning the major structural elements above and below, the need for a first-order two-way transfer system was eliminated. A one-way transfer system significantly reduced the size and the number of trusses required and reduced the overall steel tonnage of the transfer system by at least one-third, which subsequently allowed for easier maneuverability of building utilities throughout this transfer floor. The northernmost column line was cantilevered 8 ft, 6 in. beyond the shear walls below, and this structural sleight-of-hand helped reduce the forces in the transfer truss system and also helped reduce uplift force at the north ends of the shear walls. While the primary purpose of the transfer truss was to transfer gravity loading, we effectively used it as a perimeter belt truss, thereby reducing the overall building movement. This reduction of the overall building movement not only eliminated a significant number of costly and difficult-to-construct rigid connections between the precast concrete elements, but also resulted in a faster construction schedule.

SteelFab, the steel fabricator, was brought into the project at the completion of the design development phase and requested several modifications to the structure in order to ease fabrication and delivery issues. The initial transfer truss design used trusses that were 10 ft, 6 in. deep. However, SteelFab requested that they be reduced in depth to 9 ft so that they could be shipped flat on a delivery vehicle. (Shipping the trusses on an angle, as was originally planned, would have required additional permits and loading and unloading time.) SteelFab also requested welded splices for the trusses in an effort to avoid over-length material, especially due to the narrow streets surrounding the site. (The company also realized that although bolted splices would have been quicker in the field, the cost would be significantly higher, due to the size of the connection plates and quantity of bolts.)

### Steel-to-Precast Connections

While it is not uncommon for a low-rise steel structure to sit on top of a precast concrete structure, a structural steel high-rise residential tower primarily supported on top of a precast concrete building is somewhat unconventional. Also, the completely dissimilar framing layouts, which mismatched above and below, added to the magnitude of the concentrated loads at the connections.

At locations where columns from the tower above transfer directly to the precast concrete structure below, a standard four-anchor bolt connection, using Lenton Bolt Couplers embedded into the precast concrete structure below, was used. This allowed for direct transfer of tensile forces to the precast concrete wall reinforcement. It also did not leave the reinforcement protruding from the precast concrete elements, thereby preventing damage during shipping. All anchor rods were shipped loose and simply screwed

▼ Figure 2: Detail for sliding joint to allow for thermal movements.

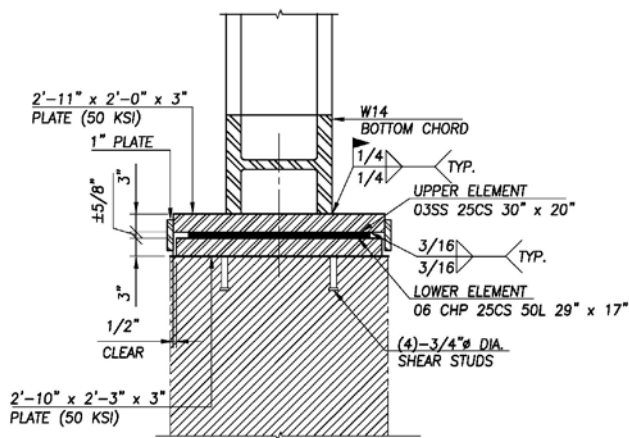

DETAIL  
3/4" = 1'-0" (2) S404

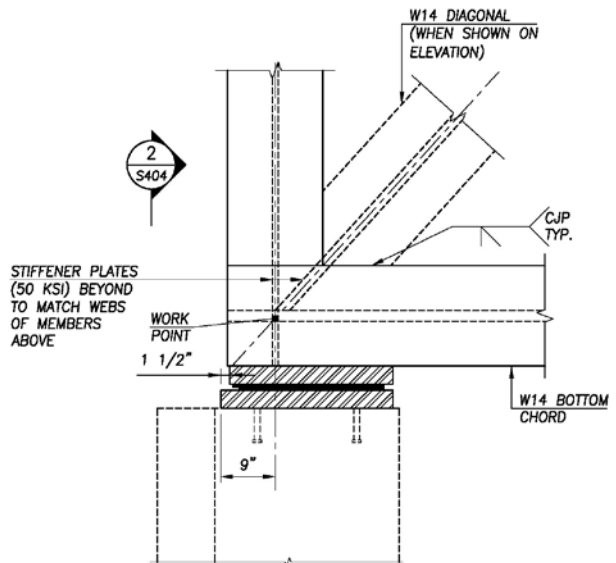

NOTE: EXTEND LARGER MEMBER THROUGH WORK POINT & ATTACH OTHER MEMBERS WITH FULL PENETRATION WELDS.

SECTION  
3/4" = 1'-0" (A) S404

into the precast concrete structure prior to the erection of the structural steel columns. Where columns with braced connections transmitted high shear forces to the walls below, shear lugs were added to the columns and box-outs in the precast structure were left in place, to be filled with grout during the column installation.

At the steel transfer truss, the connections had to accommodate SteelFab's suggestions as well as the demands of the precast concrete panel manufacturer. They also had to accommodate the localized concentrated loads. As such, each truss was supported by a column on one end and a shear wall on the other.

Differential temperature fluctuations in the garage and interstitial space where the transfers occur were a cause for concern due to the differing thermal expansion properties between the two structures. At the column support, a Teflon-coated sliding joint was introduced to permit lateral movements along the length of the truss. This allowed for thermal expansion and contraction without compromising the integrity of the underlying structure (see Figure 2).

The connections at the shear walls transfer the axial tension/compression force along with the horizontal base shear due to the lateral forces above. At the request of the precast contractor, the embedments in the tops of the shear walls at their ends needed to be minimal to limit interference with the large quantity of vertical reinforcement that was required. They also requested that connections be detailed to minimize protrusions from the formwork, thereby mitigating expensive formwork modifications; detailing the truss connections to shift the shear transfer to the center of the wall solved this problem. This connection uses a studded plate embedded in the wall along with a welded 6-in.-thick "shim" plate to reach the bottom of the truss cord. Using "loose" field-welded plates in the connection could accommodate high fabrication discrepancies, as well as any fit up issues between the steel and precast elements. At the ends of the walls, simple steel bearing plates were used with localized anchors, attached using Lenton connectors. To avoid confusion during the shop drawing detailing process and to minimize detailing

and review time, our contract drawings showed precise layouts and details to ensure that there would be minimal coordination issues between the steel and precast concrete fabricators.

The fusion of three different structural systems—a steel and precast plank building supported on a structural steel transfer system supported on a precast concrete building—required a high level of coordination among the different design-construct team members, and also demanded an especially high level of structural detailing in the construction documents. The tower was completed six months ahead of time for what was to be a 30-month schedule; significant completion of the entire complex was reached earlier this year, and occupation of the various areas has been sequenced over the last several months. The fact that this complex project was realized in minimal construction time, with fast-paced erection and minimal field changes, is a testament to what can be achieved when owners, engineers and contractors work as one cohesive team. **MSC**

**Owners**

Somerset Development Partners  
New Brunswick Development Corp. (DEVCO)  
New Brunswick Parking Authority

**Architect**

Meltzer Mandl Architects, New York

**Structural Engineer**

Severud Associates Consulting Engineers P.C., New York

**General Contractor**

AJD Construction, Leonardo, N.J.

**Steel Team**

**Steel Fabricator**

SteelFab, Charlotte, N.C. (AISC Member/AISC Certified Fabricator)

**Steel Detailer**

Prodraft, Chesapeake, Va. (AISC Member)